

# inner circle by maarten baas

# designer



**Maarten Baas,**

an independent dutch designer, often described as an author designer, with objects somewhere between art and design.

his work has been called rebellious, humorous, intellectual and theatrical. he works in several areas: limited editions, production, installations, public space, architecture, interior, decor and performances.

his work can be found in leading museum collections such as moma, victoria & albert, les arts decoratifs, san francisco museum of modern art, die neue sammlung, stedelijk museum and the rijksmuseum.

—  
photo by Kenton Thatcher

# inner circle

## by maarten baas

— **‘It’s just like in nature, where organic forms are randomly thrown together and yet always create a beautiful image’,**

Maarten Baas barely needs an introduction. For the last twenty years, the renowned Dutch designer has been capturing the hearts of design lovers with playful objects that evoke the imperfection of the human hand instead of the straight line of the machine. For his new collaboration with valerie\_objects, it is no different. After creating a quirky set of cutlery and an iconic pepper mill, valerie\_objects now proudly presents an entire set of tableware objects, from plate to water can, called Inner Circle.

What’s in a name? Two things. On the one hand, Inner Circle refers to the group of people you share the private dining table with, on the other hand the name describes Baas’ leitmotiv. ‘I discovered that all tableware items consist of circles within circles’, Baas explains. ‘At the same time, the circle is considered the most perfect symmetric shape. I played with that notion and drew spontaneous, far-from-perfect circles with a pencil’. These drawings were literally translated into tableware. The items are the materialization of imperfect, concentric circles.

Inner Circle contrives that typical human and playful Maarten Baas feel. Due to the irregular shapes, no matter how you set the table, it always looks good. ‘It’s just like in nature, where organic forms are randomly thrown together and yet always create a beautiful image’, the designer says.

Although the shapes appear playful and naive, the finishing is stunning. ‘If you create a loose shape, it is necessary to put extra effort in the detailing’, Baas states. ‘If not, your design will look scruffy and will lose its appeal’. Baas also contrasted the organic shapes with a toned-down colour palette. ‘I wanted to keep it stylish. When a chef does the plating of a dish, he does it with great care but avoids perfect geometry. There has to be a certain schwung to it. I created Inner Circle in the same way’.





**valerie** objects



**valerie** objects







**valerie** objects



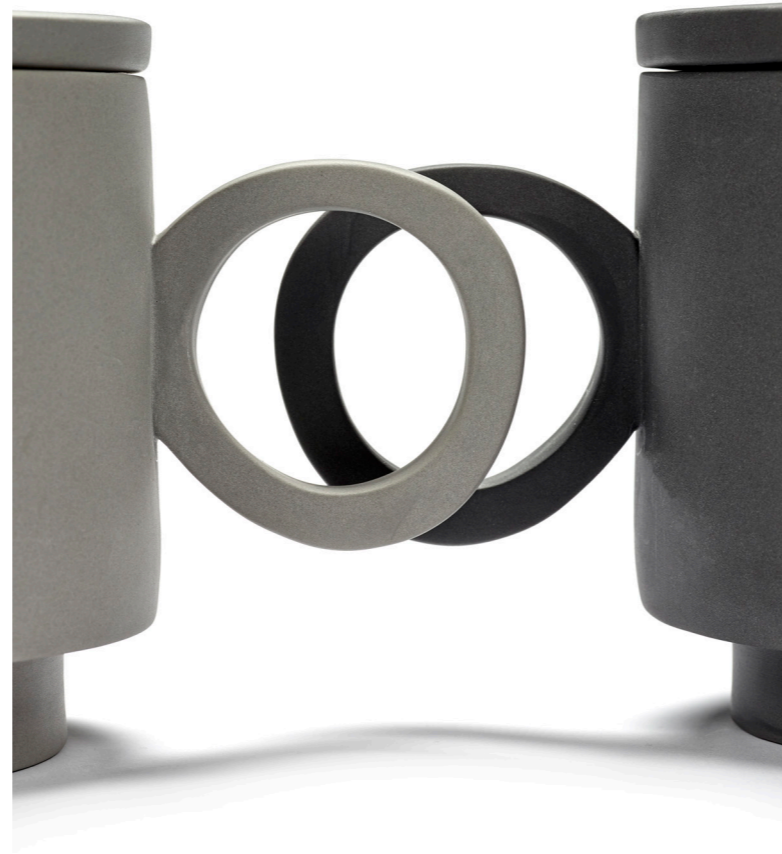







**inner circle  
2 different  
colours,  
3 different  
materials**



**valerie** objects



**valerie** objects





**valerie** objects



**valerie** objects



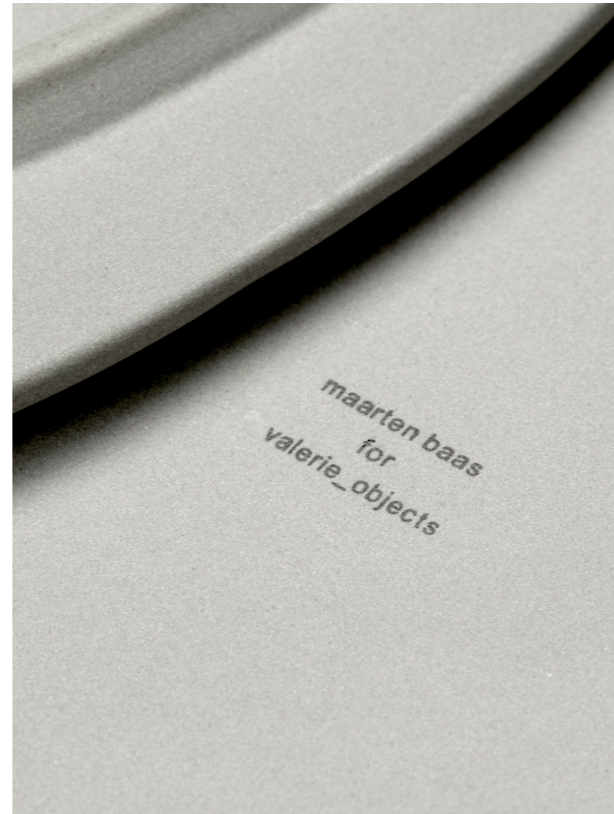

**valerie** objects







**valerie** objects





**valerie** objects

# product overview

---

## inner circle plates

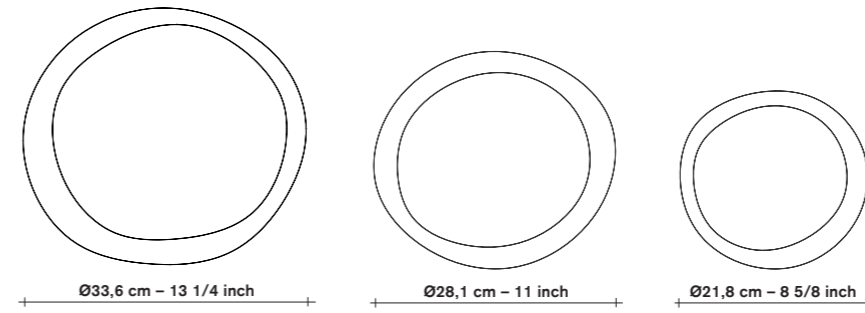

---

## inner circle tray

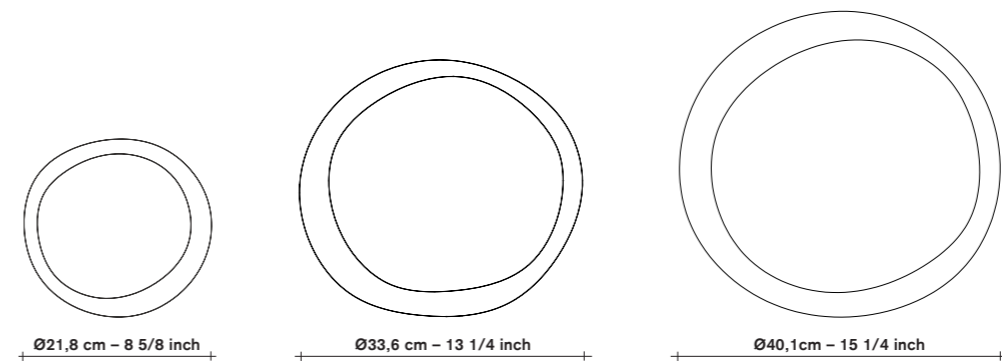

---

## inner circle bowl

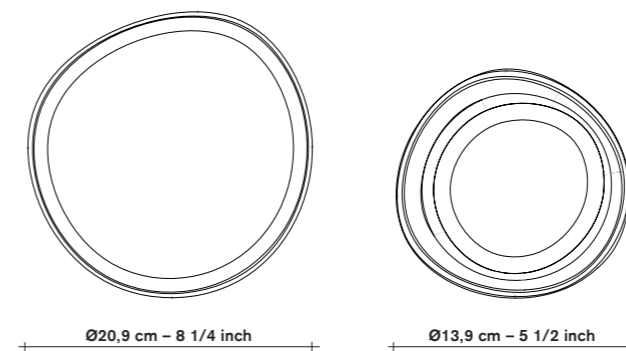

# product overview

---

inner circle  
cup

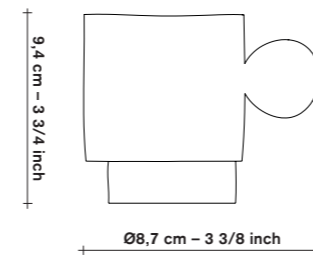
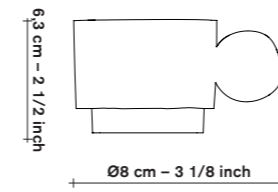
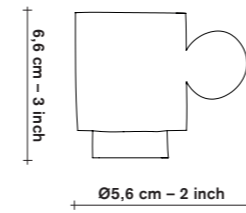

---

inner circle  
teapot

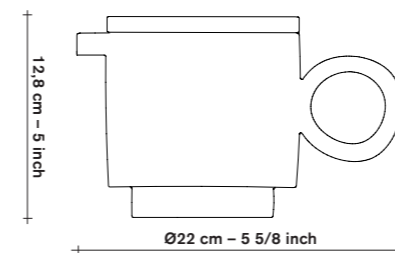



# product overview

---

## inner circle glass carafe

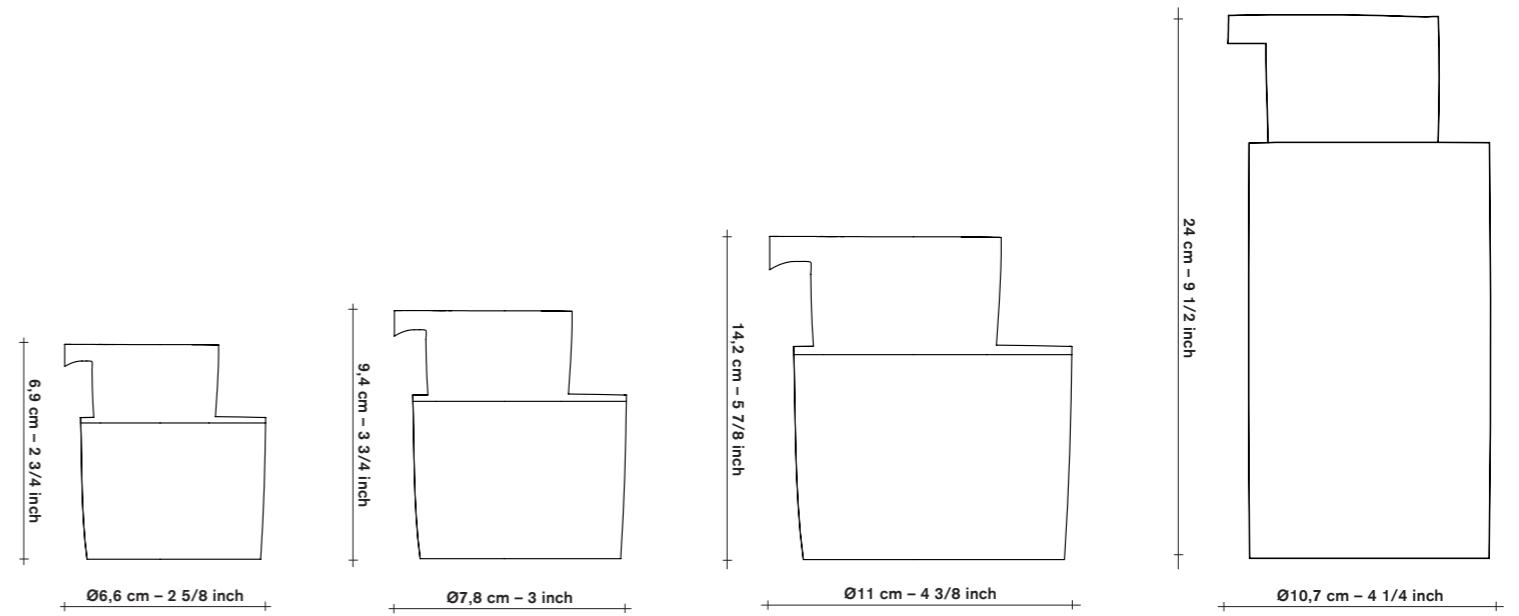

---

## inner circle glass

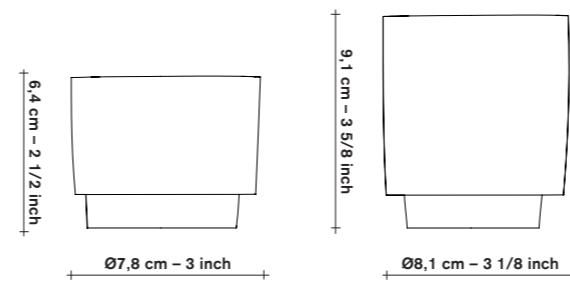

# contact

## global

general manager  
Stephanie Rosseel  
[stephanie@valerie-objects.com](mailto:stephanie@valerie-objects.com)

## retail & contract

### \_belgium

Pieter Van Den Bossche  
[pieter@valerie-objects.com](mailto:pieter@valerie-objects.com)

Pieter-Jan Delvaux  
[pj@valerie-objects.com](mailto:pj@valerie-objects.com)

### \_netherlands

Remco Van der Voort  
[remco@voort.info](mailto:remco@voort.info)

Victor Le Noble  
[victor@tuttobene.nl](mailto:victor@tuttobene.nl)

### \_denmark

Kirstine Carlsen Meijer  
[kirstine@studioxviaduct.com](mailto:kirstine@studioxviaduct.com)

Marie Jacobi  
[info@studioxviaduct.com](mailto:info@studioxviaduct.com)

### \_sweden

Agneta Ferdfelt  
[agneta@ferdfelt.se](mailto:agneta@ferdfelt.se)

### \_norway

Aina Naess + Gro Anita  
[woodsagentur@gmail.com](mailto:woodsagentur@gmail.com)

## hospitality

### \_global

hospitality director  
Nico Sas  
[Nico@serax.com](mailto:Nico@serax.com)

Camille Guinée  
[camille@serax.com](mailto:camille@serax.com)

### \_germany & france

Frank De Lombaert  
[frank@serax.com](mailto:frank@serax.com)

## press

[press@valerie-objects.com](mailto:press@valerie-objects.com)

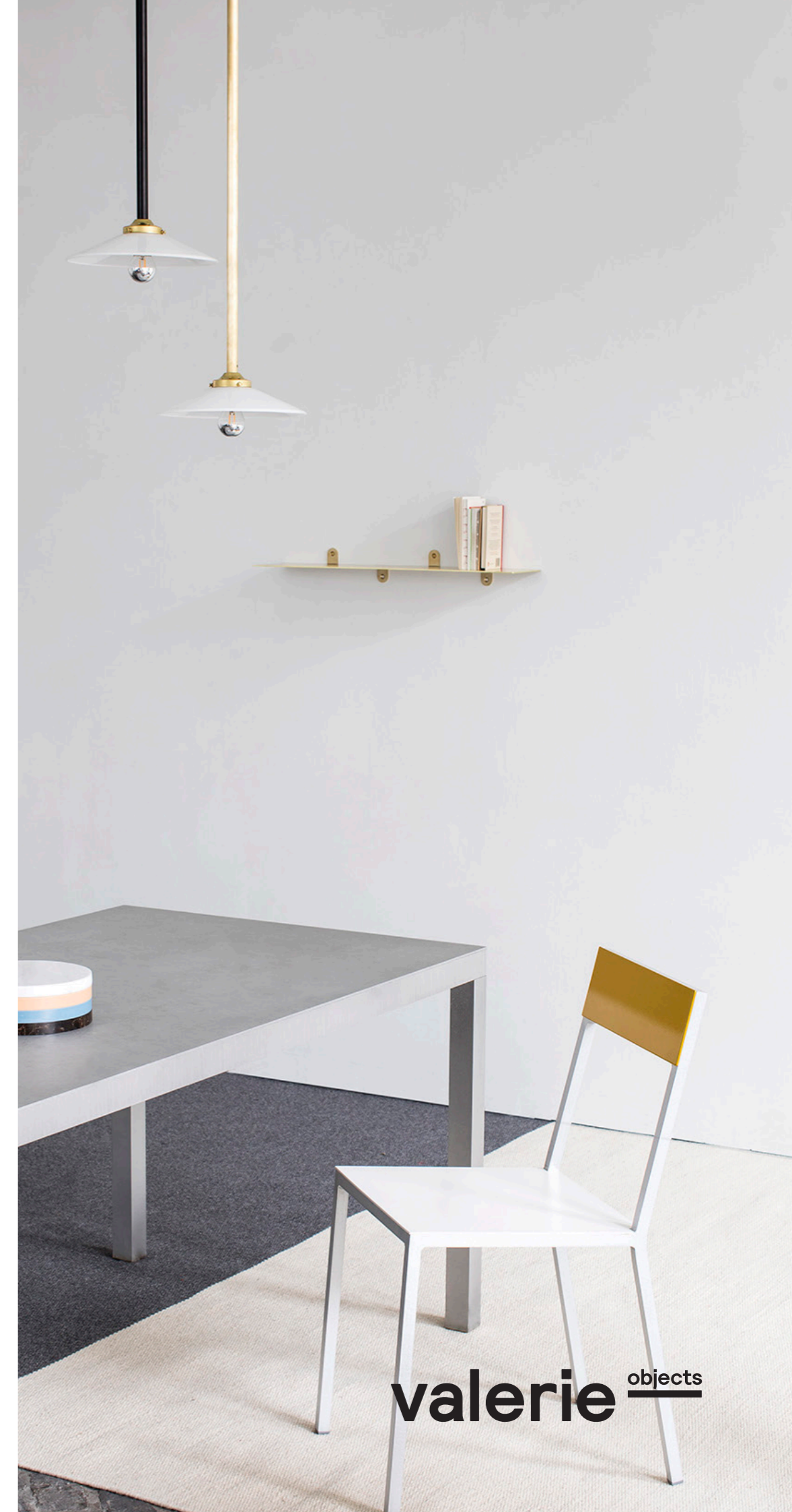

**valerie** objects

**\_all things  
good and  
beautiful**