

CODING
-241486



ISO 9001:2015
Reg. No. 000435-1-MY-1-Q&S

Read the instruction carefully. Remove all the wrapping material, staples and straps from the carton. Refer to the hardware and furniture part list for guidance. Be sure that you have all the part before you start assembling. Place all the wooden furniture part on a clean and flat soft surface, such as carpet or rubbermat to prevent from scratches.

CAUTION
KEEP ALL THE PARTS OUT OF REACH OF CHILDREN

ITEM	PHOTO	HARDWARE NAME	QTY
(A)		JCBC BOLT M6 X 60MM (RB)	2 (+ 1 extra)
(B)		JCBC BOLT M6 X 50MM (RB)	6 (+ 1 extra)
(C)		SPRING WASHER 5/16" (RB)	8 (+ 2 extra)
(D)		FLAT WASHER M6 X 13MM (RB)	2 (+ 1 extra)
(E)		SCREW PIN 15x15MM	6 (+ 1 extra)
(F)		PH 5 x 32MM (BLK)	4 (+ 1 extra)
(G)		WOOD DOWEL M10x30MM	6 (+ 1 extra)
(H)		ALLEN KEY M4 (BALL SHAPE)	1

ITEM	PHOTO	PART NAME	QTY
(1)		CHAIR BACK	1
(2)		FRONT LEG	1
(3)		SIDE RAIL (L/R)	2
(4)		CHAIR SEAT	1

CODING
-241486



ISO 9001:2015
Reg. No. 000435-1-MY-1-Q&S

1

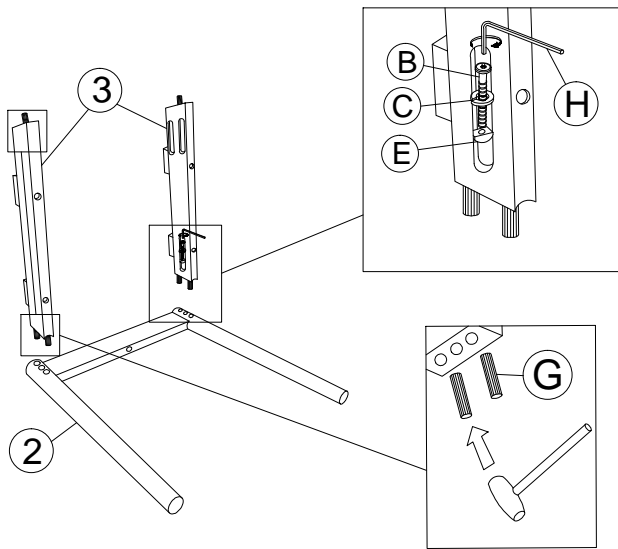

2

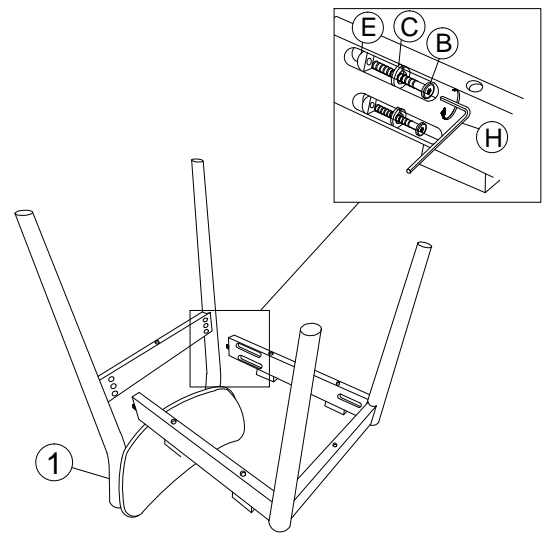

3

