

## CODING

-241154

-241156



ISO 9001:2015  
Reg. No. 000435-1-MY-1-QMS

Read the instruction carefully. Remove all the wrapping material. Staples and straps from the carton. Refer to the hardware and furniture part list for guidance. Be sure that you have all the parts before you start assembling. Place all the wooden furniture part on a clean and flat soft surface, such as carpet or rubbermat to prevent from scratches

## CAUTION

KEEP ALL THE PARTS OUT REACH OF CHILDREN

ITEM		HARDWARE NAME	QTY	EXTRA QTY
(A)		JCBC SCREW M6 X 40MM	4 PCS	1 PC
(B)		JCBC SCREW M6 X 25MM	2 PCS	1 PC
(C)		SPRING WASHER	6 PCS	2 PCS
(D)		SCREW PIN	4 PCS	1 PC
(E)		CSK CB SCREW M5 X 32MM	6 PCS	2 PCS
(F)		WOOD DOWEL M10 X 30MM	8 PCS	2 PCS
(G)		ALLEN KEY M4 (BALL SHAPE)	1 PC	-
(H)		WOOD BUTTON (BIG)	2 PCS	1 PC

ITEM		PART NAME	QTY
(1)		CHAIR LEG (L&R)	2 PCS
(2)		CENTER STRECHER ( FRONT & BACK )	2 PCS
(3)		BACK REST	1 PC
(4)		CHAIR SEAT	1 PC

CODING

-241154

-241156



ISO 9001:2015  
Reg. No. 000435-1-MY-1-QMS

1

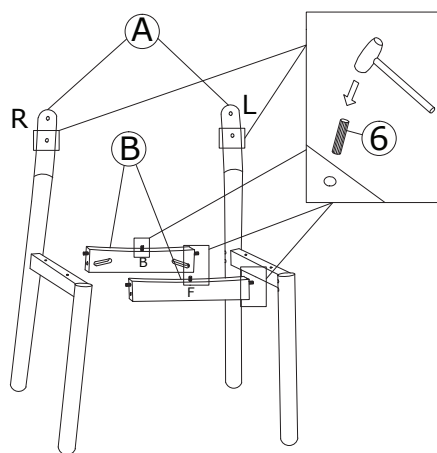

2

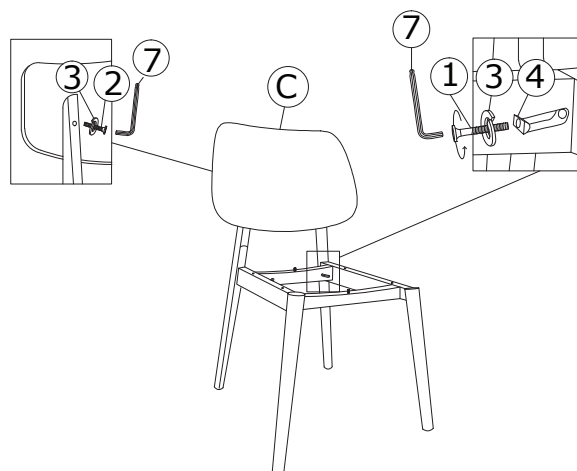

3

